

The US Army War College Quarterly: Parameters

Volume 21
Number 1 *Parameters* 1991

Article 14

7-4-1991

JOINT OPERATIONAL PROBLEMS IN THE CUBAN MISSILE CRISIS

Jonathan M. House

Follow this and additional works at: <https://press.armywarcollege.edu/parameters>

Recommended Citation

Jonathan M. House, "JOINT OPERATIONAL PROBLEMS IN THE CUBAN MISSILE CRISIS," *Parameters* 21, no. 1 (1991), doi:10.55540/0031-1723.1595.

This Article is brought to you for free and open access by USAWC Press. It has been accepted for inclusion in The US Army War College Quarterly: Parameters by an authorized editor of USAWC Press.

Joint Operational Problems in the Cuban Missile Crisis

JONATHAN M. HOUSE

Historians and political scientists continue to study the Cuban missile crisis of 1962 as a pivotal example of crisis diplomacy and national decisionmaking. The conventional version of that crisis may be summarized as follows: although there were unconfirmed reports of Soviet offensive weapons in Cuba, the Kennedy Administration was surprised and shocked when a U-2 reconnaissance flight photographed medium-range ballistic missile sites in Cuba on 14 October 1962. After a week of secret deliberations in the White House, the President announced on the evening of 23 October both the existence of the Soviet threat and the imposition of a naval quarantine. Finally, after a further week of tension and several moments at the brink of war, Nikita Khrushchev agreed to withdraw the missiles in return for a US promise not to invade Cuba and (according to some accounts) an additional promise to remove missiles from Turkey.¹

More recently, revisionists such as James G. Hershberg have suggested that long before the missiles were discovered, the Kennedy Administration was supporting a renewed effort by Cuban exiles to overthrow Fidel Castro's regime. Unlike the 1961 disaster at the Bay of Pigs, this 1962 plan, code-named "Mongoose," allegedly was to be accompanied by conventional American air and ground attacks on Cuba.²

Quite apart from the alleged Mongoose Plan, the crisis began much earlier for the Defense Department, and continued for at least a month *after* Khrushchev agreed to remove the missiles. These prolonged and serious military preparations tend to support both Hershberg and the Soviet interpretation of a "Caribbean Crisis" that began with the Bay of Pigs invasion.³ More important, however, the American contingency operation in connection with the Cuban missile crisis was the largest of the Cold War. As such, this incident illuminates continuing questions of joint operations and contingency planning.

Command and Control

To understand the planning and preparations for the invasion of Cuba, one must first review the command structure for American armed forces as it existed in 1962 (figure 1). In essence, the Army and Air Force units in the United States belonged to their own services for training and administration but to US Strike Command (STRICOM) for the process of deployment to reinforce the unified commanders. Once those forces were deployed, control would pass from STRICOM to the appropriate unified command, which planned and conducted actual operations. The service headquarters that controlled these forces were Continental Army Command (CONARC), for ground combat troops, and the Air Force's Tactical Air Command (TAC), for fighter, reconnaissance, and selected airlift units. Both CONARC and TAC had administrative, training, and doctrinal responsibilities within their respective services, responsibilities that fell outside the joint authority given to STRICOM.

Once the forces deployed for actual hostilities in the Caribbean, operational control of CONARC and TAC would pass to the US Atlantic Command, or LANTCOM. Because LANTCOM lacked Army and Air Force component headquarters in peacetime, CONARC and TAC had to function as those headquarters in the event of hostilities in the LANTCOM area. Technically, CONARC and TAC would assume the titles of Army Component, Atlantic (ARLANT) and Air Force Component, Atlantic (AFLANT) when they passed under LANTCOM control.

Planning

In April 1961, the United States had sponsored the abortive invasion of Cuba at the Bay of Pigs. The invasion was planned and carried out by the Central Intelligence Agency, but President Kennedy and his staff blamed the Joint Chiefs of Staff for a large measure of the Bay of Pigs failure, and excluded most professional soldiers from their councils in future crises. Only the soldier-intellectual General Maxwell Taylor had access to Kennedy, first as Military Assistant to the President and then in September 1962 as Chairman of the Joint Chiefs.⁴

Nevertheless, it was obvious to the Joint Chiefs and their planners that the Administration remained unreconciled to the Castro regime in Cuba,

Major Jonathan House is assigned to the Defense Intelligence Agency. A 1971 graduate of Hamilton College, he received his Ph.D. in history and his commission from ROTC at the University of Michigan in 1975. Major House has served in tactical intelligence and engineer units in the United States and Korea, and has taught at the US Army Armor School, Intelligence Center and School, and Command and General Staff College. A 1983 graduate of the staff college, he researched this article as part of a larger study of joint operations while assigned to the US Army Center of Military History.

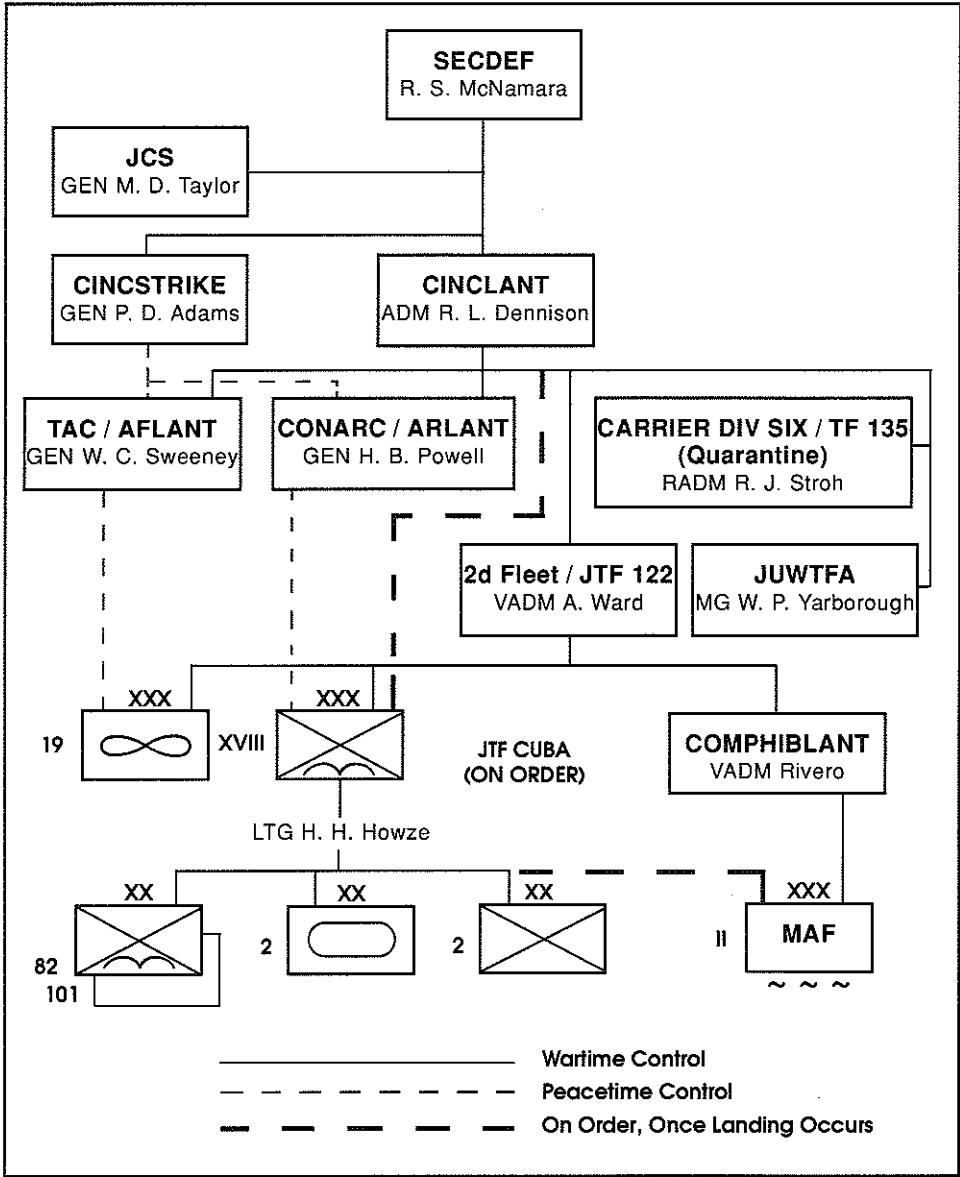

Figure 1. Chain of command, planned Cuban operations, as of 18 October 1962.

and therefore that military operations against Cuba remained a distinct possibility. In February 1962 the Joint Chiefs instructed the Commander-in-Chief, Atlantic (CINCLANT), Admiral Robert L. Dennison, to make Cuban contingency plans his highest priority.

CINCLANT and his subordinate headquarters developed three basic operations plans, known as OPLAN 312, 314, and 316.⁵ OPLAN 312 presented a variety of options for air strikes against Cuba, ranging up to an all-out campaign

to achieve air supremacy. The latter variant would have been executed before implementing either OPLAN 314 or 316.

Operations Plan 314 called for the deliberate, coordinated invasion of Cuba, with Marines landing in eastern Cuba, near Guantanamo, and the XVIII Airborne Corps seizing four airfields around Havana. The amphibious phase of the operation would be controlled by Headquarters, Second Fleet, acting as Joint Task Force (JTF) 122. Once the initial landings were completed, Headquarters, XVIII Airborne Corps, would become JTF Cuba to control all further operations. To facilitate the expected popular uprising against Castro, a separate Joint Unconventional Warfare Task Force, Atlantic, would deploy Special Forces teams and other elements into Cuba.

OPLAN 316 followed virtually the same concept of operations as 314, except that it was to be accomplished on much shorter notice—five days of warning, versus 18 days for 314. Given such short notice, the Marines would be unable to load and deploy by sea, so the initial assault would be restricted to the XVIII Airborne Corps, supported by the few Marine units already at sea or at Guantanamo. CINCLANT, Admiral Dennison, stressed the development of OPLAN 314 because he believed that an airborne assault would prove inadequate against the growing strength of the Cuban army. His Army commanders, however, all objected to the long delays necessary for the Marine elements to prepare for OPLAN 314. They argued strongly that such a delay would not only endanger any hope of surprise, but also leave masses of Army and Marine troops in crowded staging areas where they might be lucrative targets for Soviet nuclear attack. After months of discussion and frequent changes in the two plans, the Joint Chiefs of Staff finally directed a compromise on 17 October, by which OPLAN 316 would be revised as a simultaneous air and amphibious assault on seven days' warning.⁶

Regardless of which plan was executed, XVIII Airborne Corps intended to use all available airfields in Florida both to stage its troop transports during the assault and to provide a logistical base to support later operations. Throughout the summer of 1962, staff officers from Third US Army headquarters who were responsible for Army administration in the southeastern United States visited all the airbases in Florida, coordinated with local Air Force commanders for support, and planned a support structure of supply, communications, and medical units for the area.

Troops Available

Contingency plans mean nothing without the forces to execute those plans, and Third Army was hard-pressed to find the personnel for this elaborate support structure. Throughout the Cold War, the Army gave troop units in the continental United States lower priorities for personnel and equipment than units overseas, where a war might occur at any time. This shortage was

aggravated in 1962 by the beginning of conflict in Southeast Asia. In August 1962 the Army had released two National Guard divisions and 248 Army Reserve units of various sizes that had been called up for the Berlin Wall crisis of 1961. The Kennedy Administration would find it politically difficult to recall the Army Reserve and National Guard so soon after the previous mobilization.

As a result of all these factors, Continental Army Command was short-handed in terms both of available units and of the more specialized individuals within those units. The average deployable strength even in high-priority Strategic Army Corps (STRAC) units was only 80 percent of their authorized strength.

Moreover, some divisions were changing their basic organizational structure from Pentomic to Reorganization Objective Army Division (ROAD). The 2d Armored Division, which was earmarked to provide the heavy forces for Cuba, was organized on the older Pentomic structure, as were similar divisions in Europe. By contrast, the 1st Armored Division—not originally slated for involvement in Cuba—was organized under ROAD. This difference prompted the CONARC commander, General Herbert Powell, to switch the assignments of the two divisions at the last moment. Unfortunately, the 1st had been reactivated only in February 1962, in order to replace a federalized National Guard division. As a result, the newly formed, poorly equipped 1st Armored Division found itself assigned as the mechanized force for the Cuban invasion virtually overnight. This, then, was the genesis of the confused troop deployments that occurred during the crisis.⁷

Reorganization was not the only distraction for Army units in 1962. On 1 October, the bulk of XVIII Airborne Corps deployed to Oxford, Mississippi, to support federal efforts to integrate the University of Mississippi. The Corps commander, Lieutenant General Hamilton Howze, headed this operation until the situation relaxed on 10 October. This sudden deployment disrupted the Cuban planning of the XVIII Airborne Corps and its subordinate units.⁸

Origin of the Crisis

For practical purposes, military operations for the Cuban crisis began with the US discovery of Soviet IL-28 medium bombers in Cuba on 30 September, and ended with the Soviet Union's announcement on 19 November that those aircraft would be withdrawn. Only then did Kennedy end the quarantine and allow the Defense Department to relax.⁹

On 1 October 1962, Defense Secretary McNamara held his weekly meeting with the Joint Chiefs of Staff. When informed of the presence of the bombers and the strong possibility of missiles in Cuba, McNamara told the Joint Chiefs to intensify both contingency planning and the readiness of forces not only for blockade, but also for air attack or invasion of Cuba. In a letter to General Taylor the next day, McNamara enumerated six possible circumstances

that would trigger US military action, including some—such as the positioning of Soviet offensive weapons in Cuba and Cuban support of subversion elsewhere in the hemisphere—that had already occurred. The Joint Chiefs were therefore quite justified in considering invasion to be imminent. This memorandum explains why the military was thinking in terms of offensive action long after Kennedy's civilian advisors had rejected such extreme measures.¹⁰

In response to McNamara's guidance, on 1 October Admiral Dennison, the CINCLANT, directed his subordinate Army and Air Force headquarters to undertake all possible actions so as to be ready to execute the three operations plans at any time on or after 20 October. Thus, quite apart from any support for the Bay of Pigs sequel, *Mongoose*, the armed forces began preparations two weeks before missiles were actually sighted in Cuba on 14 October.

Joint Command Issues

This orderly preparation was disturbed on 19 October, when Admiral Dennison announced a major change in the command structure for OPLANs 314 and 316. He disestablished Joint Task Force 122 and announced that CINCLANT would control operations directly through his component headquarters, ARLANT (CONARC) and AFLANT (TAC). This change (figure 2) carried the seeds of disaster in case of war. It would have been a war fought by the individual components. There was no longer a joint commander on the scene to coordinate Navy and Air Force air strikes, Army paradrops, and Marine or Army amphibious landings. Dennison's reasons for this change in command structure are unclear, particularly his motive for trying to run a war in Cuba from his headquarters in Norfolk. However, by removing the JTF commander interposed between himself and the tactical units, he may have been reflecting the desires of the Kennedy Administration to maintain extremely tight, centralized control over all military operations.

In response to Admiral Dennison's decision, Continental Army Command improvised two new headquarters in Florida, one for operations (Army Component, Atlantic, or ARLANT Forward) and one for logistics (Peninsular Base Command). Both were composed of staff officers with little knowledge of previous plans. The additional burden of these two headquarters overwhelmed the makeshift communications arrangements in Florida.

At the same time, these new headquarters suffered because of belated changes in Air Force plans. Army planners had always viewed OPLAN 312 as a necessary prerequisite to execution of either OPLAN 314 or 316, but the TAC versions of these three plans had apparently been developed in isolation from each other. As a result, the Air Force bases in Florida lacked sufficient space for both fighter-bombers and troop transports. This forced recomputation of the entire plan for the airdrop, because of different flight times from alternate airbases in Florida to drop zones in Cuba.

Partial Execution

While all these military preparations occurred, the Executive Committee (an informal White House policy group) continued to develop American policy in response to the missiles. By the time President Kennedy announced that policy on 23 October, the armed forces needed to be poised to enforce it. In theory, the Joint Chiefs of Staff would transfer operational control of the appropriate CONARC and TAC forces from STRICOM to LANTCOM when execution of the operations plans for Cuba appeared imminent. In practice, this transfer was neither smooth nor clear-cut.

The immediate problem was Exercise Three Pairs, a complex series of maneuvers scheduled to occur at Ft. Hood, Texas, between 18 and 28 October 1962. As Commander-In-Chief, STRICOM (CINCSTRIKE), General Paul D. Adams had invested enormous personal effort to lease enough land around Hood

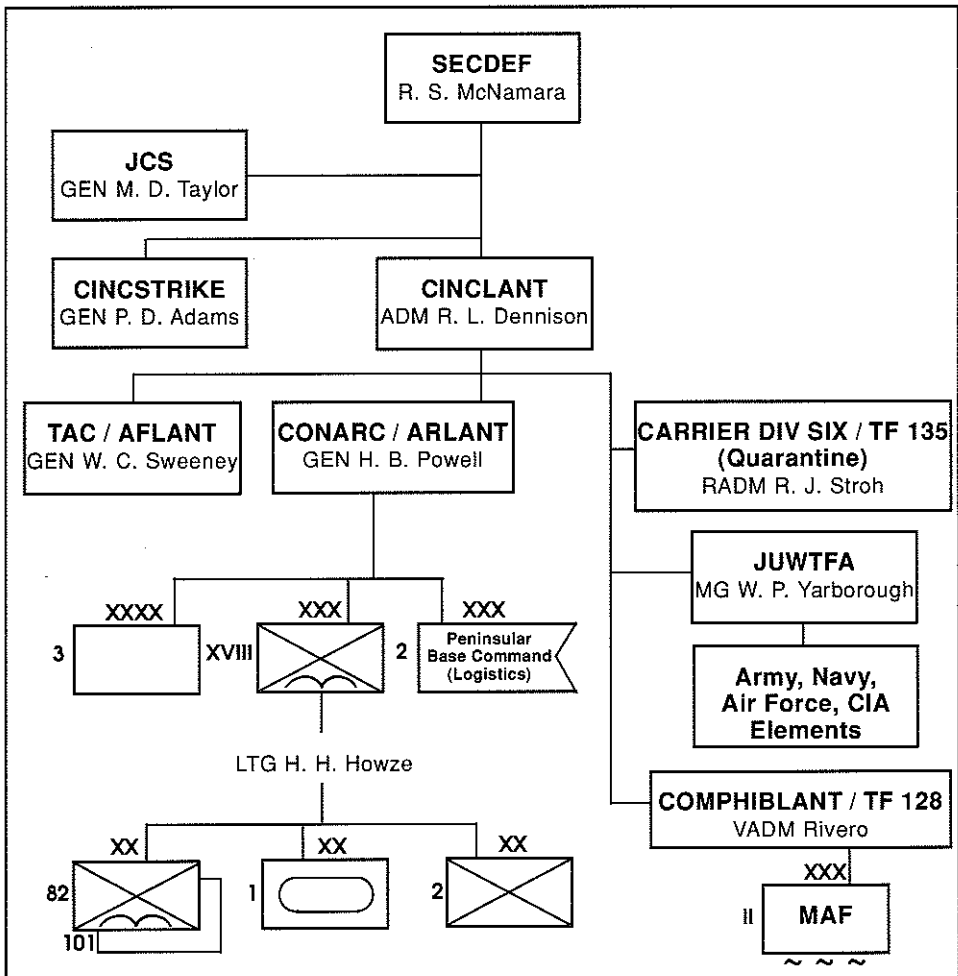

Figure 2. Chain of command, planned Cuban operations, as of November 1962.

for this exercise. Adams was naturally reluctant to abandon the exercise unless war appeared inevitable. Moreover, he believed that cancellation of the highly publicized Three Pairs would telegraph American intentions to attack Cuba.

On 20 October, however, a JCS message specifically directed the release of OPLAN 316 units from Three Pairs, and the next day the Joint Chiefs formally transferred operational control of the units involved in all three Cuban OPLANs from CINCSTRIKE to CINCLANT. Faced with this massive change, General Adams concluded that the exercise could not be salvaged and canceled it despite General Taylor's desire to continue it as a deception operation.¹¹

Even then, the transfer of control was not clear. On 21 October, the Joint Chiefs directed CINCSTRIKE to report on the status of movement and deployment of forces for OPLANs 312 and 316. This was a normal procedure when CINCSTRIKE transferred forces cleanly to an overseas unified command, but the situation here was fuzzied by the fact that CONARC/ARLANT and TAC/AFLANT were dual-hatted under CINCLANT, with five of the headquarters geographically collocated in the Ft. Monroe/Langley AFB/Norfolk area of Virginia, and with STRICOM in Florida. As a result, there was no clean break. CONARC and TAC continued to report to both STRICOM and LANTCOM as they struggled to prepare for war.

On the afternoon of 22 October, prior to the President's announcement, the Joint Chiefs of Staff decided to bring the armed forces to Defense Condition (DEFCON) 3, an increased state of readiness, and to begin positioning ground forces for possible implementation of OPLAN 316. That night, General Powell directed the movement of 1st Brigade, 1st Armored Division, and the other elements of Task Force Charlie, the mechanized force for the invasion, from Ft. Hood and Ft. Benning to Ft. Stewart. The purpose of this movement was to locate the forces near the ports of Savannah, Georgia, and Everglades, Florida, from which Task Force Charlie would deploy.

The fledgling 1st Armored Division had difficulties in its move. Nevertheless, the first elements arrived at Ft. Stewart on 25 October and the movement was completed by 10 November. From the first, however, rail storage was a problem. Because the 1st Armored had to be ready to move on short notice, the vehicles were kept mounted on flatcars rather than offloading at Ft. Stewart. Unfortunately, Ft. Stewart did not have sufficient railroad siding space to park over 660 flatcars. Third Army transportation officers turned to the rail sidings at nearby Hunter Air Force Base, on the outskirts of Savannah. At the time, however, Hunter was a Strategic Air Command base, and the local commander would not accept Army railcars until the Army's Deputy Chief of Staff for Operations, Lieutenant General Theodore W. Parker, appealed to the Air Force Chief of Staff. Thereafter Hunter provided extensive siding space.¹²

The final step was to load the first wave of Task Force Charlie aboard ships in Savannah and the Port of Everglades. In the process, staff officers

discovered numerous technical problems. For example, the two lower decks of the roll on/roll off ship USNS *Comet* lacked sufficient clearance to accommodate M48 tanks unless the commander's cupolas were removed. This same problem, on the same ship, had arisen during the 1958 deployment to Lebanon, but it had not subsequently been fixed.¹³

Despite all these obstacles and false starts, by early November the armed services were poised to invade Cuba. After eight days of loading ships, the II Marine Amphibious Force was aboard the largest collection of amphibious shipping assembled since the Korean War. The 5th Marine Expeditionary Brigade, from California, reinforced the 2d Marine Division by air and sea deployment. Seven hundred and fifty fighter-bombers waited on airfields and aircraft carriers. On 27 October President Kennedy approved McNamara's suggestion, calling to active duty 24 Air Force Reserve squadrons of troop-carrier aircraft. These aircraft made it possible to airlift the first wave of the airborne invasion, consisting of 34,800 paratroopers at Ft. Bragg and Ft. Campbell. They would be followed by surface movement of the 1st Armored Division, with elements of two infantry divisions designated for further reinforcement if necessary.¹⁴

At this point, the forces controlled by CINCLANT went into a kind of suspended animation, waiting for an execution order that never came. The

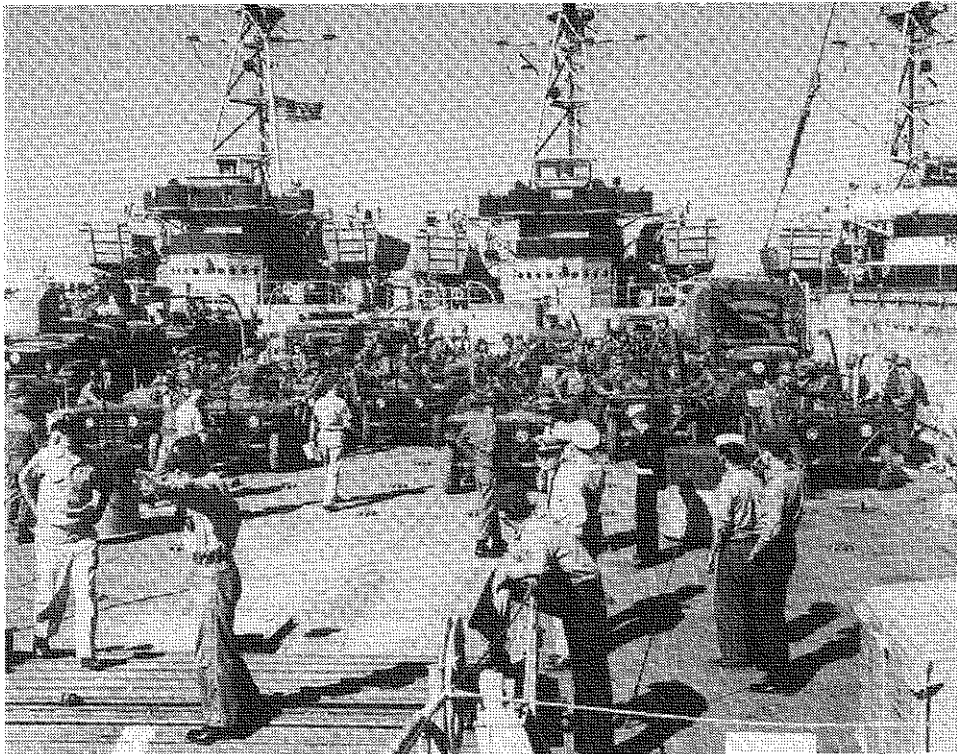

Port Everglades, Florida, 12 November 1962: Equipment of the 1st Armored Division is loaded aboard Navy ships for maneuvers during the Cuban missile crisis.

units involved remained on alert throughout November, long after the public perception of a crisis had disappeared. This prolonged alert, like the prolonged preparation prior to the discovery of missiles, indicates the seriousness with which the Administration contemplated the possibility of attacking Cuba.

In effect, the US Army had prepared for a major war without mobilizing its reserve forces, an anomaly that presaged a similar situation during the Vietnam War. This high state of readiness was achieved only at substantial cost, both in dollars and in the long-term efficiency of the services.¹⁵ The call for equipment and personnel to bring units up to strength seriously depleted the Army school system. The Army never received authority to extend soldier enlistments or recall reservists, although McNamara granted such authority to the Navy and Marines on 27 October.¹⁶

Without such mobilization measures, the Continental Army Command cannibalized its schools and support bases to meet the situation. In essence, the commanders and staff officers involved "ate the seed corn" for the sustained prosecution of the Cold War and for the approaching Vietnam conflict, although the schools eventually recovered.

During the period of sustained alert, General Powell as Commander of ARLANT asked Admiral Dennison to subordinate the Joint Unconventional Warfare Task Force, Atlantic (JUWTF/A) to ARLANT. Powell argued that the commander of the conventional invasion forces had to control the unconventional troops operating in his area. Admiral Dennison declined, instead retaining JUWTF/A directly under CINCLANT control. He indicated, however, that unconventional warfare elements actually located in proximity to invasion forces could be subordinated to such forces on a case-by-case basis. Given the complexity of any airborne or amphibious invasion and the difficulties of special operations teams engaged in the enemy's rear, Dennison's compromise might well have proved unworkable.

Conclusion

President Kennedy ended the quarantine on 21 November 1962, and within a week the return of units to their home stations was in full swing. The crisis is justly regarded as a classic case of national decisionmaking during diplomatic confrontation. Yet historians and political scientists should not study it in isolation from the military aspects of the crisis, aspects which were highly visible to the Soviet leadership and which went far beyond a quarantine of Cuba.

Since no combat ensued, the American mobilization for the Cuban missile crisis is unfortunately all but forgotten. It shared many characteristics of previous and subsequent joint operations. Continental Army Command was caught between Strike Command, which controlled its assets in peacetime, and Atlantic Command, which assumed control to implement contingency plans. A complicated joint command structure was made more so by a last-minute change

that overcentralized authority in the Commander-in-Chief, Atlantic; this change in turn required the ad hoc creation both of a joint staff at Norfolk and of service command and logistics headquarters in Florida. Coordination between the services, especially with regard to base usage in Florida, left much to be desired. The time lag required to deploy Marine amphibious units by sea when compared with the air deployment of paratroops fueled interservice rivalry. The problems of the Army in providing trained manpower for the operation clearly illustrated the importance of reserve components to conducting even limited warfare.

Those familiar with the joint command structure for the American interventions in the Dominican Republic (1965) and in Grenada (1983) will instantly recognize the equivalent structure in 1962. Atlantic Command's decision to control the operation from Norfolk, without a joint task force headquarters on the scene, was potentially disastrous. More important, the absence of a joint land forces headquarters to coordinate Army and Marine elements from the start of the invasion would have posed insoluble difficulties in coordinating airspace management, fire support, and a host of similar matters. Fortunately, the crisis subsided before the command structure's flaws were revealed in battle.

NOTES

1. This paper is part of a larger study, *The U.S. Army In Joint Operations, 1950-1983* (Washington: US Army Center of Military History, forthcoming.) For the standard interpretation of Cuba, see Graham T. Allison, *Essence of Decision: Explaining the Cuban Missile Crisis* (Boston: Little, Brown, 1971); David Detzer, *The Brink: Cuban Missile Crisis, 1962* (New York: Thomas Y. Crowell, 1979); and Raymond L. Garthoff, *Reflections on the Cuban Missile Crisis* (Washington: Brookings Institution, 1987).

2. James G. Hershberg, "Before 'the Missiles of October,'" *Diplomatic History*, 14 (Spring 1990), 163-98.

3. Garthoff, p. 3.

4. See Jeffrey G. Barlow, "President John F. Kennedy and His Joint Chiefs of Staff," Univ. of South Carolina Ph.D. dissertation, 1981, pp. 164, 177-207; General George H. Decker, Senior Officer's Debriefing by Lieutenant Colonel Dan H. Ralls, 18 December 1972, p. 12 (transcript on file in US Army Military History Institute).

5. Headquarters, US Atlantic Command, *CINCLANT Historical Account of Cuban Crisis - 1963* [sic] (U), typescript 29 April 1963, pp. 17-23 (sanitized 5 September 1986); and Jean R. Moenk, *USCONARC Participation in the Cuban Crisis, 1962* (U), Headquarters, US Continental Army Command, October 1963 (declassified 11 October 1988), pp. 6-19.

6. Moenk, pp. 16-19; see also General Paul D. Adams, Senior Officer's Debriefing by Colonel Irving Monclova and Lieutenant Colonel Marlin Long, 8 May 1975, p. 12 (transcript on file at the Military History Institute).

7. Moenk, p. 115; Joseph R. Wisnack, "Old Ironsides' Response to the Cuban Crisis," *Army*, April 1963, pp. 26-30.

8. Headquarters, 82d Airborne Division, "The Role of the 82d Airborne Division in the Cuban Crisis, 1962 (U)," typescript report, 12 April 1963, p. 5 (unclassified paragraphs only); Moenk, pp. 105-07.

9. Alan Yarmolinsky, "Department of Defense Operations During the Cuban Missile Crisis," 13 February 1963, sanitized version edited by Dan Caldwell in *Naval War College Review*, 32 (June-July 1979), 84, 88.

10. McNamara's 2 October memorandum is quoted in Joseph F. Bouchard, "Use of Naval Force in Crises: A Theory of Stratified Crisis Intervention," Stanford University Ph.D. dissertation, 1988, pp. 528-29.

11. Moenk, pp. 12, 108-11; Wisnack, pp. 27-30.

12. Headquarters, Third US Army, "Historical Narrative on the Cuban Crisis (U)," typescript dated 26 June 1963, p. 3 and Appendix 8 (Transportation) to Annex C (Logistics), p. 4; Moenk, pp. 120-21.

13. Moenk, pp. 129-34.

14. Yarmolinsky, pp. 88, 92; *CINCLANT Historical Account*, pp. 156-58.

15. Third Army, "Historical Narrative," Annex D (Comptroller), pp. 2-4; and Moenk, p. 122.

16. Yarmolinsky, pp. 97-98; Third Army, "Historical Narrative," Annex C (Logistics), p. 13; Moenk, p. 227.