

9-1-2002

## Clausewitz's Center of Gravity: Changing Our Warfighting Doctrine--Again!

Antulio J. Echevarria Dr.  
SSI

Follow this and additional works at: <https://press.armywarcollege.edu/monographs>

---

### Recommended Citation

Echevarria, Antulio J. Dr., "Clausewitz's Center of Gravity: Changing Our Warfighting Doctrine--Again!" (2002). *Monographs, Books, and Publications*. 815.  
<https://press.armywarcollege.edu/monographs/815>

This Book is brought to you for free and open access by USAWC Press. It has been accepted for inclusion in Monographs, Books, and Publications by an authorized administrator of USAWC Press.

**CLAUSEWITZ'S CENTER OF GRAVITY:  
CHANGING OUR WARFIGHTING  
DOCTRINE—AGAIN!**

**Antulio J. Echevarria II**

**September 2002**

\*\*\*\*\*

The views expressed in this report are those of the author and do not necessarily reflect the official policy or position of the Department of the Army, the Department of Defense, or the U.S. Government. This report is cleared for public release; distribution is unlimited.

\*\*\*\*\*

Comments pertaining to this report are invited and should be forwarded to: Director, Strategic Studies Institute, U.S. Army War College, 122 Forbes Ave., Carlisle, PA 17013-5244. Copies of this report may be obtained from the Publications Office by calling (717) 245-4133, FAX (717) 245-3820, or via the Internet at [Rita.Rummel@carlisle.army.mil](mailto:Rita.Rummel@carlisle.army.mil)

\*\*\*\*\*

Most 1993, 1994, and all later Strategic Studies Institute (SSI) monographs are available on the SSI Homepage for electronic dissemination. SSI's Homepage address is: <http://www.carlisle.army.mil/usassi/welcome.htm>

\*\*\*\*\*

The Strategic Studies Institute publishes a monthly e-mail newsletter to update the national security community on the research of our analysts, recent and forthcoming publications, and upcoming conferences sponsored by the Institute. Each newsletter also provides a strategic commentary by one of our research analysts. If you are interested in receiving this newsletter, please let us know by e-mail at [outreach@carlisle.army.mil](mailto:outreach@carlisle.army.mil) or by calling (717) 245-3133.

ISBN 1-58487-099-0

## FOREWORD

Over the last 25 years, the center of gravity concept has grown increasingly central to the U.S. military's warfighting doctrine. It has been hailed by each of the Services and the Joint community as the cornerstone of the operational art; and it has come to occupy a common place in the vocabulary of professional soldiers. It is somewhat surprising, therefore, that, over the last quarter-century especially, the term has come to have so many different meanings.

In this monograph, the author, Lieutenant Colonel Antulio Echevarria II, cuts through the myriad interpretations surrounding the concept and gets back to the original idea as conceived by its author, the Prussian military theorist, Carl von Clausewitz. In going back to the original concept, Lieutenant Colonel Echevarria reveals that Clausewitz intended the center of gravity to function much as its counterpart in the mechanical sciences does, that is, as a focal point. Lieutenant Colonel Echevarria thus argues, quite persuasively, that the Clausewitzian center of gravity is not a strength, nor a weakness, nor even a source of strength. A center of gravity is the one element within a combatant's entire structure or system that has the necessary centripetal force to hold that structure together. This is why Clausewitz wrote that a blow directed against a center of gravity will have the greatest effect. The monograph concludes with recommendations for revising Joint and Service doctrine so that they will reflect a more accurate and coherent definition of a center of gravity. It also offers some considerations for the war planner when applying the concept.

DOUGLAS C. LOVELACE, JR.  
Director  
Strategic Studies Institute

## BIOGRAPHICAL SKETCH OF THE AUTHOR

ANTULIO J. ECHEVARRIA II, a lieutenant colonel in the U.S. Army, is currently assigned as the Director of Strategic Research at the Strategic Studies Institute. He graduated from the U.S. Military Academy in 1981, was commissioned as an armor officer, and has held a variety of command and staff assignments in Germany and Continental United States; he has also served as an assistant professor of European history at the U.S. Military Academy; Squadron S3 of 3/16 Cavalry; Chief of BN/TF and Bde Doctrine at the U.S. Army Armor Center at Fort Knox; as an action officer at the Army After Next project at HQ TRADOC, Ft. Monroe, VA; and as a speechwriter for the U.S. Army Chief of Staff. He is a graduate of the U.S. Army's Command and General Staff College, the U.S. Army War College, and holds M.A. and Ph.D. degrees in History from Princeton University. He has published articles in a number of scholarly and professional journals to include the *Journal of Strategic Studies*, *Journal of Military History*, *War in History*, *War & Society*, *Parameters*, *Joint Force Quarterly*, *Military Review*, and *Airpower Journal*. His book, *After Clausewitz: German Military Thinkers before the Great War*, was published by the University Press of Kansas in the spring of 2001.

## SUMMARY

The center of gravity has become one of today's most popular military concepts despite the fact that its origins extend back to the early industrial-age. Clausewitz's military center of gravity (CoG) and the CoG of the mechanical sciences share many of the same properties: neither is a strength or a source of strength, *per se*, but rather a *focal point* where physical (and psychological) forces come together. The U.S. military's doctrinal publications—especially Joint Pub 3-0, *Doctrine for Joint Operations*, and Joint Pub 5-00.1, *Joint Doctrine for Campaign Planning*—should be revised to reflect a more accurate definition of the CoG.

### **U.S. Military Doctrine and the CoG Concept.**

Over the last 2 decades especially, the U.S. military has struggled both to understand the CoG concept as developed by Clausewitz, and to find practical ways to apply it. In the process, however, it has drifted away from Clausewitz's original idea. For example, each of the services—shaped by different roles, histories, and traditions—tended to view the CoG concept in their respective images. The CoG concept has, therefore, been fitted with many guises over the years. The Joint community attempted—though with only limited success—to pull the various service perspectives together into a single definition with the publication of Joint Pub 3-0 in 1995. In other words, Joint Pub 3-0 strove to achieve an “authoritative” consensus by drawing together many of the services' predilections. However, in so doing, it defined CoGs too broadly and offered no real method for determining them.

The recently released Joint Pub 5-00.1 (January 2002) builds upon Joint Pub 3-0 and attempts to provide a general method for determining CoGs. However, the process that

Joint Pub 5-00.1 describes for determining a CoG actually leads us *not* to a CoG, but to a set of critical (physical or psychological) capabilities. This process appears to have borrowed from Dr. Joseph Strange's popular "CG (center of gravity)—CC (critical capabilities)—CR (critical requirements)—CV (critical vulnerabilities)" approach. In theory, Strange's approach linked CoGs (which he defined as "dynamic agents of action or influence" to CVs in a way that war planners could put to practical use. However, because any number of "dynamic agents of action or influence" can exist within a given nation or within a given battlespace, his definition fails to offer a way to focus one's efforts and other resources on something that will prove decisive. Strange's method only brings war planners to the enemy's centers of critical capability, rather than to an actual CoG.

### **Clausewitz's Center of Gravity.**

Clausewitz's original definition follows the physics analogy more closely than previous analyses of his work have appreciated. In fact, it is not a source of strength or a critical capability, but a focal point that is essentially effects-based, rather than capabilities-based. In modern elementary physics, which was about the state of the mechanical sciences in Clausewitz's day, a CoG represents the point where the forces of gravity converge within an object. Striking at the CoG with enough force will usually cause the object to lose its balance, or equilibrium, and fall. A CoG is, therefore, *not* a source of strength, but a factor of balance.

A closer look at the German text shows that Clausewitz never used the term "source" (*Quelle*). Moreover, the concept remains valid only where the enemy possesses sufficient "unity" or "interdependence" (*Zusammenhang*) to act as a single body. Before applying the concept in war planning, therefore, we must ask ourselves whether we can consider the enemy to act as a single entity. If so, we should

look for connections among the various parts of an adversary, or adversaries, in order to determine what holds them together. This is the CoG.

Furthermore, Clausewitz's CoG focuses on achieving a specific effect, the collapse of the enemy. Hence, it is an effects-based approach, rather than a capabilities-based one and it resembles an emerging concept called Effects-Based Operations (EBO) more than it does the capabilities-based notion that underpins today's doctrine. Another important point is that Clausewitz did not distinguish between tactical, operational, or strategic CoGs. *The CoG is defined by the entire system (or structure) of the enemy, not by a level of war.* In addition, Clausewitz emphasized that we should look for CoGs only in wars designed to defeat the enemy completely. Only the vast amount of energy and other resources that go into wars aimed at achieving decisive victory can cause CoGs and their areas of influence to emerge.

### **Toward a Simple Method.**

However, getting the definition of a CoG correct is only half the battle. War planners need a practical method for determining what a specific adversary's CoG is. Such as:

Step 1: *Determine whether identifying and attacking a CoG is appropriate for the type of war we are going to wage.*

Step 2: *Determine whether the adversary's whole structure or system is sufficiently connected to be treated as a single body.*

Step 3: *Determine what element has the necessary centripetal force to hold the system together.*

Additional Recommendations:

- Redefine CoG as follows: Centers of Gravity are *focal points* that serve to hold a combatant's entire system or structure together and that draw power from a variety of sources and provide it with purpose and direction.



- Refrain from applying the concept to every kind of war; reduce the competition that can occur between CoGs and political-military objectives.
- Identify where the connections—*and gaps*—are in an enemy's entire structure or system before deciding whether a CoG actually exists; CoGs only apply where a combatant is sufficiently interconnected to act with unity.
- Focus more effort on identifying the specific *effect(s)* to be achieved by attacking a CoG.
- Continually reassess CoGs. However, reevaluate the need to attack CoGs that are extremely transitory.
- Resist “salami-slicing” the adversary into tactical, operational, and strategic CoGs. The bulk of our efforts and intermediate objectives should focus on destroying *the* CoG.

In conclusion, the CoG concept is one of several of Clausewitz's ideas—such as friction in war, culmination of the attack, the roles of chance and uncertainty—that have a quality that transcends his day and makes them relevant to our own. However, we must apply it judiciously, especially in today's post-industrial era in which “networked” opponents armed with chemical, biological, radiological, nuclear, and high-yield explosive weapons can operate in a globally decentralized manner.

## **CLAUSEWITZ'S CENTER OF GRAVITY: CHANGING OUR WARFIGHTING DOCTRINE—AGAIN!**

The center of gravity has become one of today's most popular military concepts despite the fact that its origins extend back to the early industrial-age. First introduced by the Prussian military theorist, Carl von Clausewitz, in the late 1820s, the idea now appears in the doctrinal literature of all U.S. military services, and in many European militaries as well. Despite its popularity, a great deal of confusion still surrounds the basic concept. Its definition has evolved quite substantively over time; and, even after decades of effort, identifying an opponent's center of gravity (CoG) remains more art—and often an arcane one at that—than science. This state of affairs is rather ironic since Clausewitz originally borrowed the idea of the CoG from the sciences, from mechanical science—or physics—to be exact. Why the great military theorist chose to apply an essentially scientific concept to warfare, which he considered neither an art nor a science, lies beyond the scope of this monograph.<sup>1</sup> Suffice to say that Clausewitz's military CoG and the CoG of the mechanical sciences share many of the same properties: neither is a strength or a source of strength, per se, but rather a *focal point* where physical (and psychological) forces come together. The U.S. military's doctrinal publications—especially Joint Pub 3-0 *Doctrine for Joint Operations* and Joint Pub 5-00.1, *Joint Doctrine for Campaign Planning*—should be revised to reflect a more accurate definition of the CoG.<sup>2</sup>

### **U.S. Military Doctrine and the Center of Gravity Concept.**

Over the last 2 decades especially, the U.S. military has struggled both to understand the center of gravity concept as developed by Clausewitz, and to find practical ways to

apply it. In the process, however, it has drifted away from Clausewitz's original idea. The concept has evolved from a Jominian "decisive point"—vital geographic features, boundaries between army groups, and lines of communication—into a key "source of strength."<sup>3</sup> In some circles, it was used interchangeably with the German term *Schwerpunkt*, usually translated as "main effort," and became synonymous with the location where one's combat forces were most densely concentrated.<sup>4</sup> Some maneuver theorists, for instance, saw the CoG as a "critical vulnerability" that, if neutralized, would paralyze the enemy and achieve a quick decision, *à la* blitzkrieg.<sup>5</sup> Striving for this goal distinguished maneuver warfare from its less attractive counterpart, brute-force attrition-style warfare.

In addition, each of the services—shaped by different roles, histories, and traditions—tended to view the CoG concept in their respective images. The U.S. Army and U.S. Navy, for example, typically thought in terms of a single CoG, which usually resided at the core of one's land or naval power and provided the "source" of one's physical and psychological capacity to fight.<sup>6</sup> The U.S. Air Force, on the other hand, pursued the notion of multiple CoGs, each of which could be "targeted" from the air to achieve the paralysis of the enemy.<sup>7</sup> And, finally, the U.S. Marine Corps (USMC), with the difficult mission of conducting amphibious forcible entry operations, preferred for a time to think of the CoG as a key weakness, or critical vulnerability, the exploitation of which would give it a decisive advantage.<sup>8</sup> The CoG concept has, therefore, been fitted with many guises over the years.

The Joint community attempted—though with only limited success—to pull the various service perspectives together into a single definition with the publication of Joint Pub 3-0 in 1995.<sup>9</sup> This publication asserted that the essence of the operational art resided in being able to mass effects against the enemy's sources of power, or CoGs, to gain a decisive advantage. It defined CoGs as those "charac-

teristics, capabilities, or locations from which a military force derives its freedom of action, physical strength, or will to fight.”<sup>10</sup> Joint Pub 3-0 also stated or implied that CoGs existed for every level of war, and for all types of war. Presumably, defeating tactical CoGs would facilitate the accomplishment of tactical objectives, which, in turn, would contribute to the defeat of operational CoGs, the destruction of which then would assist in the accomplishment of operational objectives, and so on, until we achieve our national security objectives. At the strategic level, CoGs might include a military force, an alliance, national will or public support, a set of critical capabilities or functions, or national strategy itself. At the operational and tactical levels, they would generally consist of the principal *source of combat power*—such as modern, mobile, or armored combat forces—that can assure, or prevent, accomplishment of the mission. In other words, Joint Pub 3-0 strove to achieve an “authoritative” consensus by drawing together many of the services’ predilections. However, in so doing, it defined CoGs too broadly and offered no real method for determining them.

The recently released Joint Pub 5-00.1 (January 2002) builds upon Joint Pub 3-0 and attempts to provide a general method for determining CoGs. It defines the CoG in a manner similar to Joint Pub 3-0 with the exception that the phrase “sources of strength” replaces the term “locations.”<sup>11</sup> Also, the Executive Summary in Joint Pub 5-00.1 provides some much-needed elaboration: CoGs consist of “those aspects of the adversary’s *overall capability* that, theoretically, if attacked and neutralized or destroyed will lead either to the adversary’s inevitable defeat or force opponents to abandon aims or change behavior.”<sup>12</sup> The CoG thus derives from the collective sum of the enemy’s capabilities, and it is, therefore, a capabilities-based definition, despite the presence of terms such as “characteristics” or “sources of power.” Furthermore, Joint Pub 5-00.1 stresses the importance of linking CoGs to “critical vulnerabilities,” so that one can attack the enemy’s

CoG through weak points in his overall system. In a manner reminiscent of the current USMC approach, CoGs and critical vulnerabilities are treated as different, but complementary concepts.<sup>13</sup> The purpose of identifying a CoG is, reasonably enough, to enable us to focus our efforts and limited resources on something that will achieve decisive results. The purpose of identifying critical vulnerabilities is to allow us to be *smart* about how we attack CoGs. As Brigadier General (Retired) Huba Wass de Czege explained, using the concept of a CoG in war planning “leads you to see very quickly that some vulnerabilities are interesting but a waste of resources because they do not lead anywhere useful in the end.”<sup>14</sup>

However, the process that Joint Pub 5-00.1 describes for determining a CoG actually leads us *not* to a CoG, but to a set of critical (physical or psychological) capabilities. This process appears to have borrowed from Dr. Joseph Strange’s popular “CG-CC-CR-CV” approach.<sup>15</sup> Strange correctly showed that the Joint (and individual service) definitions of CoGs were flawed and lacked precision. They tended to equate CoGs with vulnerabilities or strengths and paid too little attention to psychological centers of power. To rectify that, he offered a “fix” that redefined CoGs as “dynamic agents of action or influence” or, more specifically, “moral, political and physical entities which *possess* certain characteristics and capabilities, or benefit from a given location/terrain.”<sup>16</sup> Accordingly, his CG-CC-CR-CV approach defined a CoG, such as a key combat force, by those critical capabilities (CCs) that enabled it to function as a CoG. Those CCs—the ability to shoot, move, and communicate—in turn, have critical requirements (CRs)—such as open lines of communication and supply—that enable the CCs to keep functioning. A CR that is inadequately protected—such as the North Korean army’s lines of communication near Inchon—constitutes a critical vulnerability (CV). If attacked and neutralized, these CVs would contribute to defeating the enemy’s CoG.

In theory, Strange's approach linked CoGs to CVs in a way that war planners could put to practical use. However, because any number of "dynamic agents of action or influence" can exist within a given nation or within a given battlespace, his definition fails to offer a way to focus one's efforts and other resources on something that will prove decisive. What makes one dynamic agent more important than another? Strange's fix does not actually build upon the Clausewitzian definition—in which the CoG functions as a focal point. Instead, his CoGs amount to *centers of critical capabilities*. In fact, as his own approach makes clear, what makes his CoGs important are their CCs, making this a capabilities-based concept. To be sure, Strange's approach can help war planners make the important linkages between critical strengths or capabilities and critical vulnerabilities. However, his method will only bring war planners to the enemy's actual CoG—as opposed to merely one of his centers of critical capability—by coincidence.

The Joint Pub 5-00.1 definition and its approach to determining CoGs, therefore, beg the question: Why not just call centers of critical capabilities what they are?—critical centers or critical points. Identifying the enemy's centers of critical capabilities can be very useful. Indeed, as we shall see under Clausewitz's definition, an adversary might not have a CoG, or at least not one that we can attack. In those situations, we would do well to focus our efforts on destroying the enemy's critical centers. It stands to reason that defeating them will eventually lead to the accomplishment of our objectives.

As the next section will show, Clausewitz's original definition follows the physics analogy more closely than previous analyses of his work have appreciated. As such, it differs substantively from the prevailing idea that a CoG is a source of strength or a critical capability. In fact, it is essentially an effects-based, rather than a capabilities-based concept.

## Clausewitz's Center of Gravity.

The quintessential cerebral savage, Clausewitz borrowed a number of intellectual constructs, theories, and concepts from the leading philosophers, scientists, and other thinkers of his day in order both to understand and to describe the various aspects of war that he observed.<sup>17</sup> Several of his concepts—friction, polarity, and center of gravity—are analogies or metaphors drawn from the mechanical sciences. In particular, the original German text of *Vom Kriege (On War)* reveals that Clausewitz used the term CoG—expressed primarily as *Schwerpunkt*—more than 50 times, though not all of them refer to the military concept.<sup>18</sup> He appears to have derived his idea of the CoG after being influenced by a series of lectures presented by German physicist Paul Erman, a professor at both the University of Berlin and the Prussian *Allgemeine Kriegsschule (War College)*. Clausewitz served as director of the War College from 1818 to 1830, and we know that he and Erman had at least a cordial relationship in which they exchanged ideas related to the mechanical sciences.<sup>19</sup>

In modern elementary physics, which was about the state of the mechanical sciences in Clausewitz's day, a CoG represents the point where the forces of gravity converge within an object.<sup>20</sup> At that point an object's weight is balanced in all directions. A physical object can be thought of in two ways: as a composite of many smaller particles, each of which is acted upon by gravity; or as a single object, which is acted upon by gravity only at a single point (See Figure 1).<sup>21</sup> Understandably, physicists prefer the latter, since it makes other calculations concerning the interaction of force and matter much easier. However, physicists also acknowledge that a CoG amounts to little more than a mathematical approximation, since gravity acts upon *all* the points in an object simultaneously.

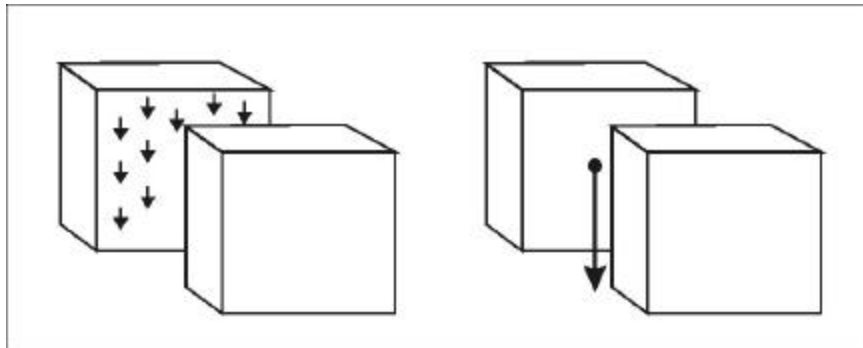

**Figure 1. Cross-section of a Cube Showing How Forces of Gravity Operate.**

Calculating a CoG for a simple, symmetrical object—a ruler, a rock, a boomerang—is not difficult. The CoG for a ruler is in the middle of it. The CoG for a sphere lies at its geometric center. Interestingly, the CoG for a boomerang, though not difficult to calculate, does not lie on the object itself, but in the space between the “V” (See Figure 2).<sup>22</sup> On the other hand, calculating the CoG for complex objects—such as a bolos or a human being with multiple moving parts—is more difficult. Such objects must be artificially “frozen” in time and space. When a complex object changes the distribution of its weight, its body position, or if external weight is added, the CoG requires recalculation (See Figures 3 and 4).



**Figure 2. Center of Gravity of a Boomerang.**





**Figure 3. A Stationary Soldier's CoG.**

**Figure 4. A Moving Soldier's CoG.**

Striking at the CoG with enough force will usually cause the object to lose its balance, or equilibrium, and fall. A CoG is, therefore, *not* a source of strength, but a factor of balance. An infantryman's strength, for example, might derive from his muscles, his brains, or his weapons, or any combination of these, but they relate to his CoG only so far as he needs to be *balanced* to use them. Also, a CoG is not a weakness. An infantryman might be physically weak, intellectually challenged, or wanting for weapons, but these conditions have little to do with his equilibrium. Strictly speaking, then, a CoG is neither a strength nor a weakness, though striking it can compromise a strength or exploit a weakness. If one could direct a blow with enough force against the infantryman's CoG, he could be laid low, despite the sum of his strengths and weaknesses, because his CoG is connected to those things by means of his physical body.

Most of the U.S. military's definitions of CoGs derive from Sir Michael Howard's and Peter Paret's English translation of Clausewitz's *On War*, especially Book VI (Defense) and Book VIII (War Plans). From these passages we learn that a CoG is "always found where the mass is concentrated most densely," that it is "*the hub of all power and movement on which everything depends*," and that it emerges from the "dominant characteristics of both belligerents."<sup>23</sup> Unfortunately, as the passage below reveals, this translation, while the best available for many years, creates the false impression that CoGs are akin to sources of strength:

The first principle is that the ultimate substance of enemy strength must be traced back to the fewest possible **sources**, and ideally to one alone. The attack on these **sources** must be compressed into the fewest possible actions—again, ideally, into one.

The task of reducing the **sources** of enemy strength to a single center of gravity will depend on: 1. The distribution of the enemy's political power . . . 2. The situation in the theater of war where the various armies are operating.<sup>24</sup>

In fact, a closer look at the German text shows that Clausewitz never used the term "source" (*Quelle*). Instead, he advised tracing the full weight (*Gewicht*) of the enemy's force (*Macht*) to as few CoGs as possible.<sup>25</sup> As in the previous physics example, the CoG connects the soldier's various strengths without being a strength itself. A more literal translation of the above passage appears below:

The first principle is: To trace the full **weight** (*Gewicht*) of the enemy's **force** (*Macht*) to as **few centers of gravity** as possible, when feasible, to one; and, at the same time, to reduce the blow against these centers of gravity to as few major actions as possible, when feasible, to one.

. . . reducing the enemy's **force** (*Macht*) to one center of gravity depends, first, upon the [enemy's] political connectivity [or unity] itself . . . and, second, upon the situation in the theater of

war itself, and which of the various enemy armies appear there.<sup>26</sup>

Further examination of Clausewitz's references to the CoG throughout the German text of *On War* reveals, first of all, that the concept remains valid only where the enemy possesses sufficient "unity" or "interdependence" (*Zusammenhang*) to act as a single body:

Just as the center of gravity is always found where the mass is most concentrated, and just as every blow directed against the body's center of gravity yields the greatest effect, and—more to the point—the strongest blow is the one delivered by the center of gravity, the same is true in war. The armed forces of every combatant, whether an individual state or an alliance of states, have a certain *unity* and thus a certain **interdependence** [or **connectivity**] (*Zusammenhang*); and **where such interdependence exists, one can apply the center of gravity concept** Accordingly, there exist *within* these armed forces certain *centers of gravity which, by their movement and direction, exert a decisive influence over all other points*; and these centers of gravity exist *where* the forces are most concentrated. However, just as in the world of inanimate bodies where the effect on a center of gravity has its proportions and its limits determined by the interdependence of the parts, the same is true in war.<sup>27</sup>

In other words, before applying the concept in war planning, we must ask ourselves whether we can consider the enemy to act as a single entity. If so, we should look for connections among the various parts of an adversary, or adversaries, in order to determine what holds them together. In 1809, for example, Napoleon had to fight on two fronts, against Anglo-Spanish forces in Spain and against the Austrians in central Europe. Although they had a common enemy, the Anglo-Spanish and Austrian forces did little to coordinate their efforts. Hence, it would have been correct for Napoleon to look for two CoGs, one on each front. As Clausewitz stated, the degree of unity formed by military forces and the geographical spaces in which they have to fight can create *more than one CoG*. He advocated tracing

multiple CoGs back to a single one whenever possible. Yet, he allowed for the possibility that one specific CoG might not exist. The key question we must ask, then, is whether the enemy's forces are *connected* sufficiently so that actions against him in one area will still have a decisive effect on him in other areas.

Second, just as in physics, the CoG refers to the thing that holds the enemy's force together, enabling it to act as a single entity. Indeed, when we reexamine the German text in one of the popular passages from Book VIII in which Clausewitz described the CoG as it applies to war planning, we find the emphasis on the CoG as a focal point becomes clearer:

What theory can admit to thus far is the following: Everything depends upon keeping the dominant characteristics of both states in mind. From these emerge a certain center of gravity, a **focal point** (*Zentrum*) of force and movement, upon which the larger whole depends; and, it is against the enemy's center of gravity that the collective blow of all power must be directed.<sup>28</sup>

To find the CoG in any particular situation, then, we must look for the thing that is providing a certain *centripetal*, or center-seeking, force (as opposed to centrifugal, which is outward-seeking) for the enemy. Clausewitz pointed out, for example, that in the February 1814 campaign against France, the allies' CoG lay more with Prussia's Field Marshal Gebhard Leberecht Blücher than with Austria's Prince Karl Philip von Schwarzenberg, even though the latter had a larger army (140,000) than the former (100,000). "Blücher," Clausewitz explained, "although [numerically] weaker than Schwarzenberg, was nonetheless the more important adversary due to his enterprising spirit; hence, the center of gravity lay more with him and *it* pulled the others in his direction."<sup>29</sup> In the actual campaign, Napoleon (75,000) first defeated Blücher's Prussian army, then turned on Schwarzenberg's Austrians and drove them back. Nonetheless, both Blücher's and

Schwarzenberg's armies recovered and defeated Bonaparte one month later.<sup>30</sup> Clausewitz criticized Napoleon's decision, arguing that the French Emperor should have continued hammering away at Blücher—the allies' CoG—until the Prussian force was completely defeated. Such a victory, in Clausewitz's view, would have induced the Austrians to withdraw as well. As in the mechanical sciences, therefore, Clausewitz's military CoGs have a centripetal quality; they represent a *focal point*, a location where forces come together.

Clausewitz gave several examples of such focal points. The CoGs of Alexander the Great, Gustavus Adolphus, Charles XII of Sweden, and Frederick the Great, for instance, resided in their respective armies. In different circumstances, the personalities of key leaders, a state's capital, or its network of allies and their community of interest might serve as CoGs.<sup>31</sup> What all of these various elements have in common is *not* that they are sources of power, but that they perform a centripetal or centralizing function that holds power systems together and, in some cases, even gives them purpose and direction. Strictly speaking, an armed force is not a "source" of power. Rather, it serves as a focal point that draws and organizes power from a variety of sources: a population base (recruits); an industrial base (weapons and materiel); and an agricultural base (foodstuffs). The same holds true for the personalities of key leaders, state capitals, or alliance networks. These things draw raw power from different sources and refine, organize, and redirect it.

Furthermore, Clausewitz's CoG focuses on achieving a specific effect, the collapse of the enemy. Hence, it is an effects-based approach, rather than a capabilities-based one. To be sure, the two approaches are linked. Attacking specific capabilities produces certain effects. Achieving certain effects often requires attacking specific capabilities. Indeed, one could say that these approaches represent the proverbial two sides of the same coin. In the capabilities-based approach, the first step is to identify the

key enemy strength or capability that could prevent us from achieving our objective. In the effects-based approach, the first step is to identify the effect we want to achieve and then to determine what actions we should take to achieve it. Frequently those actions might go well beyond merely neutralizing or destroying specific capabilities. In a manner of speaking, the capabilities-based approach seeks a negative aim, destruction of a certain capability. The effects-based approach, on the other hand, pursues a positive aim because it seeks to create a definite effect. The U.S. military has gotten into the habit of narrowly focusing on the former. It could well benefit from a broader approach of the latter.

In one sense, Clausewitz's effects-based CoG resembles an emerging concept called Effects-Based Operations (EBO) more than it does the current capabilities-based notion, with the exception that only one particular effect is sought—total collapse of the enemy.<sup>32</sup> For Clausewitz's effects-based approach, the effect and the objective—total collapse of the enemy—were always the same. EBO has the benefit, as retired General Anthony Zinni remarked, of forcing political and military leaders to focus on the specific effects that they want military (and non-military) action to achieve.<sup>33</sup> When asked to describe effects-based operations, one senior official replied that they were akin to dissolving "the *glue*" that holds a table together, rather than striking at its individual legs.<sup>34</sup> Thus, while the officer's analogy is flawed in that it uses a static object to describe something that has a dynamic nature, the similarities in the two approaches are clear.

Like EBO, Clausewitz's CoG requires the ability to predict, with some reasonable probability, how to achieve at least first and second-order effects, and possibly more. That said, it is important to point out that Clausewitz eschewed prescriptive formulae and considered the calculation of a CoG a matter of "strategic judgment" (*strategische Urteil*) at the highest levels.<sup>35</sup> It is a matter of judgment and, given Clausewitz's distaste for prescriptive formulae, it is

doubtful that he would have approved of some of the current efforts to develop them by means of new kinds of information technology and software. Educating senior leaders to develop their strategic judgment in order to make such determinations, on the other hand, was something he certainly would have supported. This theme runs consistently throughout *On War*.

Another important point is that Clausewitz did not distinguish between tactical, operational, or strategic CoGs. *The* CoG is defined by the entire system (or structure) of the enemy, not by a level of war. Consider the example of the soldier (Figures 3 and 4); he can have only one CoG at a time. According to Clausewitz, a local commander might determine a center of gravity for the portion of the enemy's forces that lay before him, providing those forces demonstrated sufficient independence from the remainder of the enemy's forces. However, this separate CoG would only amount to a *local* rather than a tactical or operational CoG. For us to speak of a tactical CoG, the tactical level of war would have to exist independent of the operational and strategic levels of war. Similarly, for CoGs to exist at the operational and strategic levels of war, those levels of war would have to have an existence separate from the rest of warfare. This notion defies the principle of unity—or interconnectedness—that German military thinkers from Clausewitz to Heinz Guderian had ascribed to warfare.<sup>36</sup> For better or worse, the German way of war did not formally recognize the operational level of war until after 1945, when it was heavily influenced by U.S. doctrine. This is not to say that understanding how to link engagements together into a “campaign” is not important; only that a campaign should not become an end in itself, or a justification for elevating the operational art above strategy.

Clausewitz's own references to strategy throughout *On War* rarely rise above contemporary campaign strategy. He never addressed the integration of the nonmilitary elements of national power into a “grand strategy” of sorts. He appears to have thought mainly in terms of the

employment of the military element of power; hence, his focus is primarily on military strategy (and that almost exclusively from a land perspective). Even his discussions of operations within single or multiple theaters take place at the level of military strategy, that is, from the standpoint of purely military ends, ways, and means. Accordingly, we should consider his CoG to be a strategic concept, a way. It is clear from his discussions in *On War* that he would have supported the idea of individual CoGs based on geographic circumstances. At the same time, it is highly unlikely that he would have supported assigning CoGs by horizontally “slicing” war into tactical, operational, and strategic levels.

In addition, Clausewitz emphasized that we should look for CoGs only in wars designed to defeat the enemy completely. Only the vast amount of energy and other resources that go into wars aimed at achieving decisive victory can cause CoGs and their areas of influence to emerge.<sup>37</sup> Perhaps more important, in such wars military and political objectives—the total political and military defeat of the enemy—essentially complement one another. In such wars we want to achieve the total collapse of the enemy and so we want to strike at his CoG. In limited wars, on the other hand, CoGs—which focus on the total collapse of the enemy—tend to compete with the typically more restricted political objective(s). For example, during the Gulf War the ground component planning staff of U.S. Central Command (CENTCOM) spent more hours attempting to identify the Iraqi CoG than planning how to defeat it.<sup>38</sup> Ironically, under Clausewitz’s concept, determining the Iraqi CoG would have been unnecessary since the Gulf War was not a war of annihilation. Simply translating the war’s strategic objectives—expulsion of Iraqi forces from Kuwait and reduction of Iraqi offensive capability—into operational and tactical objectives should have given coalition forces all the operational guidance they would have needed to succeed.<sup>39</sup> This is not to say that the CoG concept can only apply in wars of annihilation, but to



point out that it is neither appropriate nor necessary in all cases.

To sum up, Clausewitz's CoG is a *focal point*, not a strength nor a weakness, nor even a source of strength. Second, CoGs are found only where sufficient connectivity exists among the various parts of the enemy to form an overarching system (or structure) that acts with a certain unity, like a physical body. Unless the enemy's parts have sufficient connectivity, he may not necessarily have a CoG. Third, CoGs possess a certain centripetal force that acts to hold an entire system or structure together. A blow at the enemy's CoG would throw him off balance or, put differently, cause his entire system (or structure) to collapse. Fourth, the concept necessitates viewing the enemy holistically, as a system. Finally, identifying CoGs is not appropriate for all types of wars.

As we have seen, Joint doctrine's definition of CoGs departs from Clausewitz's original concept. By equating CoGs to critical capabilities, strengths, or sources of strength, the Joint definition refers more to centers of critical capability than centers of gravity. Moreover, as Figure 5 (modified from Figure II-2, extracted from Joint Pub 5-00.1) reveals, the flawed definition leads to some mischaracterizations regarding an adversary's (or our own) CoG that could detrimentally affect war planning.

### **Toward a Simple Method.**

However, getting the definition of a CoG correct is only half the battle. War planners need a practical method for determining a specific adversary's CoG.<sup>40</sup> The method should be simple, in keeping with Clausewitz's dictum that in war even the simplest thing is difficult, and yet it should make use of the best intelligence available and accommodate revision as the result of rigorous analysis.

*Step 1: Determine whether identifying and attacking a CoG is appropriate for the type of war we are going to wage.*

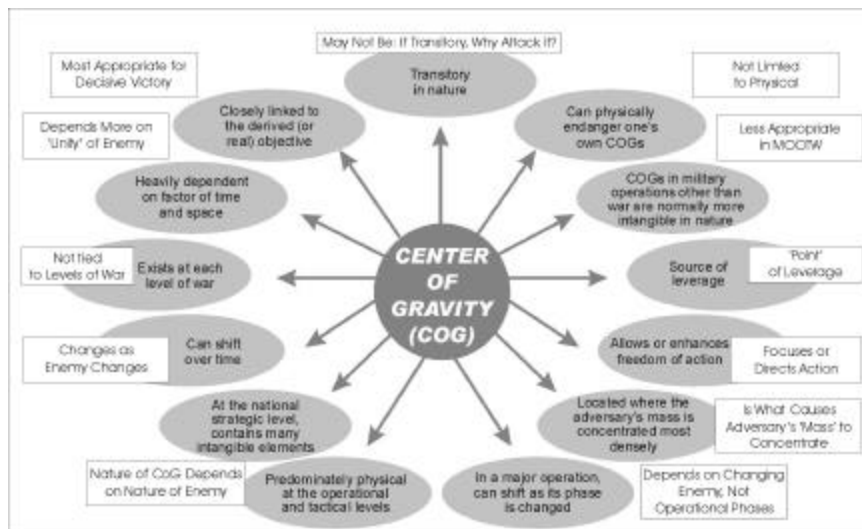

**Figure 5. Characteristics of the Adversary's Centers of Gravity.**

For example, the campaign against Al Qaeda, though part of the larger global war on terrorism, is essentially a war that, for the United States at least, cannot end without the neutralization or destruction of that terrorist group; hence, it is the kind of war in which the identification and pursuit of a CoG serves a constructive purpose.

Step 2: *Determine whether the adversary's whole structure or system is sufficiently connected to be treated as a single body.* Al Qaeda has numerous cells operating globally, most of which do not know of the existence of the others. At least some of these cells—or certain individuals within them—appear to have been linked to the group's leadership by networked electronic communications. Messages and commands were thus passed via the internet, cellular phones, and other electronic devices. It is also possible that a fair number of cells already have orders—and have had them for some time—that they will attempt to execute at a certain time and place, if they receive no other orders to the contrary. Thus, the physical

links are somewhat tenuous. Successful operations against Al Qaeda cells in Europe will not likely cause those in Singapore to collapse, particularly as a new breed of “super cells” appears to be emerging that can act even more independently.<sup>41</sup> However, the group’s psychological—or ideological—links appear strong. If they are not particularly well-linked physically, the cells do appear to be fairly united ideologically. It might be best, therefore, to seek an ideological CoG.

Step 3: *Determine what element has the necessary centripetal force to hold the system together.* One ideological element does appear to have sufficient centrifugal force to hold Al Qaeda together, that is its avowed “hatred of apostasy.”<sup>42</sup> It is probably that hatred, rooted in a radical branch of Islam—rather than Osama bin Laden or another individual leader—that serves as the group’s CoG. While bin Laden appears to have done much of the ground work to establish Al Qaeda, it does not appear that his removal will cause his organization to collapse. Most analysts and intelligence sources claim that if bin Laden were captured or killed, another leader would simply take his place.<sup>43</sup> That leader can only turn out to be either more or less as effective as bin Laden. Thus, Al Qaeda’s leadership really amounts to a center of critical capability, something we want to neutralize but not something that will end the war. The hatred of apostasy is what draws raw power—recruits, money, and the support of other states—and serves to motivate the group’s members to wage their particular style of asymmetric warfare. For this group, apostasy seems to serve as the root cause of the poverty, corruption, the spread of Western influences, and the social and political violence that plague many Muslim societies. It will likely continue to serve in such a capacity after bin Laden is removed. Decisively defeating Al Qaeda, therefore, will require neutralizing that CoG. However, accomplishing that will mean employing the diplomatic and informational elements of national power in a deliberate campaign to discredit the notion that apostasy is the root cause of injustice against

Muslims. It is a campaign that will, to be sure, require the support of moderate branches of Islam. Yet, it will also require deliberate military action against terrorist cells in the field so that this brand of Muslim extremism becomes associated with “failure” to achieve its ends.

Additional Recommendations:

To put its doctrinal definitions of CoG more in line with Clausewitz’s idea and thereby bring the concept back under control, U.S. military doctrine in general, and Joint Pub 3-0 and Joint Pub 5-00.1 in particular, should redefine the CoG as follows:

- Centers of Gravity are *focal points* that serve to hold a combatant’s entire system or structure together and that draw power from a variety of sources and provide it with purpose and direction.

- War planners should refrain from applying the concept to every kind of war (or operation) so as to eliminate or reduce the competition that can occur between CoGs and political-military objectives. We must ask ourselves whether the total military collapse of the enemy is commensurate with our political objectives and end state.

- If so, then war planners should identify where the connections—*and gaps*—are in an enemy’s entire structure or system before deciding whether a CoG actually exists. The CoG concept does *not* apply in a situation in which the enemy is *not* connected enough to act with unity. Also, given the anticipated proliferation of chemical, biological, radiological, nuclear, and high-explosive (CBRNE) weapons over the next decade or so, some situations are likely in which it is dangerous to assume that the individual segments of the enemy can be defeated by a single knock-out blow. If several of Al Qaeda’s cells were armed with CBRNE, for instance, striking against one cell could trigger a massive retaliation event. The continued proliferation of CBRNE and information technologies could very well make the CoG concept academic in the future.

- Employing Clausewitz's CoG concept means that we will have to train ourselves to think more about the specific *effect(s)* we want to achieve and less about the capabilities we want to destroy, though without denigrating the importance of those capabilities.

- CoGs can, of course, change in the course of a conflict if, for example, allies enter or leave the fight, or other changes occur within the combatants' respective power structures. We must, therefore, reassess any previous determination of a CoG. However, we should reevaluate whether we need to attack CoGs that are so transitory that once one is destroyed another quickly takes its place. If that occurs, perhaps we have only found a center of critical capability rather than a CoG.

- We should resist "salami-slicing" the adversary into tactical, operational, and strategic CoGs. The bulk of our efforts and intermediate objectives should focus on destroying *the* CoG. Creating sub-CoGs is artificial, unless our opponent is too dispersed or decentralized to have one CoG. Yet, even in such cases, we may find it possible to trace those individual CoGs back to a central one.

In conclusion, the U.S. military has come to a doctrinal fork in the road. On the one hand, it can modify the CoG concept, changing the term into a center of criticality so that it more accurately reflects what the definition actually says. If it chooses this path, the U.S. military should drop the term center of gravity from its lexicon entirely. On the other hand, if it wishes to retain the CoG concept so that it can continue to focus its efforts against something that would force an adversary to collapse, then it should redefine the CoG concept as a focal point. If it chooses this path, the U.S. military would have a concept that behaves more like an actual CoG. It would also find itself in a better position to incorporate and apply information-age concepts like Effects-Based Operations.

To be sure, the U.S. military is under no obligation to accept a concept developed nearly two centuries ago by a

military theorist who was influenced by a distant culture and who had different conceptual tools available to him. Yet, each of the services believes its CoG derives from Clausewitz's. Presumably, the original concept had something of value that attracted military artists to it in the first place. Indeed, that original fascination was not misplaced. The concept does have value. However, we need to get back to the original idea to understand and benefit from that value. Many of Clausewitz's ideas—friction in war, culmination of the attack, the roles of chance and uncertainty—have a quality that transcends his day and makes them relevant to our own. The CoG concept is one of them. However, we must apply it judiciously. The risks of misapplying it, especially in today's post-industrial era in which "networked" opponents armed with CBRNE can operate in a globally decentralized manner, are too great.

## ENDNOTES

1. In Book I, Chapter 2 of *On War*, Clausewitz concluded that warfare is neither a science nor an art. Its outcomes are too unpredictable to consider it a science, and it involves forces that react when acted upon, so it can not be an art, like painting. Carl von Clausewitz, *On War*, Indexed ed., Michael Howard and Peter Paret, eds. and trans., Princeton: Princeton University Press, 1989. Hereafter cited as *On War*.

2. Department of Defense, *Doctrine for Joint Operations*: Joint Pub 3-0, Washington, DC: U.S. Department of Defense, February 1995; Department of Defense, *Joint Doctrine for Campaign Planning*: Joint Pub 5-00.1, Washington, DC: U.S. Department of Defense, January 2002.

3. Department of the Army, *Operations*: FM 100-5, Washington, DC: U.S. Department of the Army, 1986, pp. 179-180, Appendix B, identified key command posts, key terrain, unit boundaries, logistics bases, and lines of communication as CoGs. Jomini defined a decisive point as anything "whose attack or capture would imperil or seriously weaken the enemy." John Shy, "Jomini," in *The Makers of Modern Strategy: From Machiavelli to the Nuclear Age*, Peter Paret, ed., Princeton: Princeton University Press, 1986, pp. 152-154. For example, USMC doctrine, like most U.S. doctrine, currently defines CoGs as *key or important* "sources of strength." Department of the Navy, *Warfighting*:

Marine Corps Doctrinal Publication 1, Washington, DC: U.S. Department of the Navy, 1997, p. 46; and *Strategy*: MCDP 1-1, p. 86; and *Campaigning*: MCDP 1-2, p. 41.

4. William S. Lind, *Maneuver Warfare Handbook*, Boulder: Westview, 1985, pp. 107-110.

5. Robert R. Leonard, *The Art of Maneuver: Maneuver Warfare Theory and Airland Battle*, Novato, CA: Presidio, 1991, esp. pp. 20-24.

6. FM 100-5, 1993, p. 6-13; Department of the Navy, *Naval Warfare*: NDP 1, Washington, DC: U.S. Department of the Navy, March 1994, p. 72.

7. See John A. Warden III, *The Air Campaign: Planning for Combat*, Washington, DC: NDU Press, 1988, pp. 9-10; and John A. Warden III, "The Enemy as a System," *Airpower Journal*, Vol. 9, No. 1, Spring 1995, pp. 40-55; and Department of the Air Force, *Air Force Doctrine Document 1*, Washington, DC: U.S. Department of the Air Force, September 1997, p. 79.

8. Department of the Navy, *Warfighting*: FMFM 1, Washington, DC: U.S. Department of the Navy, 1989, p. 85.

9. Department of the Navy, *Warfighting*: MCDP 1, Washington, DC: U.S. Department of the Navy, June 20, 1997, pp. 44-45; and Department of the Army, *Operations*: FM 100-5, Washington, DC: U.S. Department of the Army, 2001, pp. 5-7, generally follow the Joint Pub 3-0 definition.

10. Joint Pub 3-0, p. GL-4.

11. Joint Pub 5-00.1, p. II-6.

12. Joint Pub 5-00.1, p. ix. Emphasis added.

13. For examples of this approach, see: *Warfighting*: MCDP 1, 1997, p. 46; and *Strategy*: MCDP 1-1, 1997, p. 86; and *Campaigning*: MCDP 1-2, 1997, p. 41.

14. Brigadier General (retired) Huba Wass de Czege, "Clausewitz: Historical Theories Remain Sound Compass References: The Catch Is Staying on Course," *ARMY*, Vol. 38, No. 9, September 1988, p. 42.

15. Joseph Strange, *Centers of Gravity and Critical Vulnerabilities: Building on the Clausewitzian Foundation So That We Can All Speak the Same Language*, Perspectives on Warfighting Series No. 4, 2d Ed., Quantico, VA: Marine Corps Association, 1996.

16. Strange, *Centers of Gravity*, pp. 47-48 and 143. Emphasis original.

17. For example, Clausewitz borrowed from German philosophers Immanuel Kant, Georg Hegel, Friedrich Schiller, and Germany's famous literary figure, Wilhelm Goethe. Peter Paret, *Clausewitz and the State*, New York: Oxford University Press, 1976.

18. *Schwerpunkt* is the term used most frequently; it appears at least 53 times, though some uses do not reflect the sense of a CoG. Clausewitz also used the terms *Centra gravitatis*, *Kern* or core, and *Zentrum* or center, at times.

19. Paret, *Clausewitz*, pp. 310-311.

20. Geoff Jones, Mary Jones, and Phillip Marchington, *Cambridge Coordinated Science: Physics*, Cambridge: Cambridge University Press, 1993, pp. 52-55.

21. In an environment where gravity does not exist, a CoG is replaced by a center of mass, CoM, meaning where an object's mass is most heavily concentrated.

22. Jones, *et al.*, *Physics*, p. 53.

23. *On War*, pp. 485-486, 595-596. Emphasis added.

24. *On War*, p. 617. Emphasis added. In fairness to Howard and Paret, they admit that at times their translation was more interpretive than literal. They could not have foreseen the extent to which the U.S. military would embrace the CoG concept and adhere to their interpretation literally.

25. See Carl von Clausewitz, *Vom Kriege*, 19th Ed., Intr. by Werner Hahlweg, Regensburg: Pustet, 1991. Hereafter, *Vom Kriege*

26. "Der erste ist: das Gewicht der feindlichen Macht auf so wenig Schwerpunkte als möglich zurückzuführen, wenn es sein kann, auf einen; wiederum den Stoß gegen diese Schwerpunkte auf so wenig Haupthandlungen als möglich zurückzuführen, wenn es sein kann, auf eine; endlich alle untergeordnete Handlungen so untergeordnet als möglich zu halten. Mit einem Wort, der erste Grundsatz ist: so konzentriert als möglich zu handeln. Der zweite Grundsatz: so schnell als möglich zu handeln, also keinen Aufenthalt und keinen Umweg ohne hinreichenden Grund. Das Reduzieren der feindlichen Macht auf einen Schwerpunkt hängt ab: Erstens von dem politischen Zusammenhang derselben . . . Zweitens von der Lage des



Kriegstheaters, auf welchem die verschiedenen feindlichen Heere erschienen." *Vom Kriege*, pp. 1009-1010. Emphasis added.

27. "So wie sich der Schwerpunkt immer da findet, wo die meiste Masse beisammen ist, und wie jeder Stoß gegen den Schwerpunkt der Last am wirksamsten ist, wie ferner der stärkste Stoß mit dem Schwerpunkt der Kraft erhalten wird, so ist es auch im Kriege. Die Streitkräfte jedes Kriegführenden, sei es ein einzelner Staat oder ein Bündnis von Staaten, haben eine gewisse Einheit und durch diese Zusammenhang; wo aber Zusammenhang ist, da treten die Analogien des Schwerpunktes ein. Es gibt also in diesen Streitkräften gewisse Schwerpunkte, deren Bewegung und Richtung über die anderen Punkte entscheidet, und diese Schwerpunkte finden sich da, wo die meisten Streitkräfte beisammen sind. So wie aber in der toten Körperwelt die Wirkung gegen den Schwerpunkt in dem Zusammenhang der Teile ihr Maß und ihre Grenze hat, so ist es auch im Kriege." Emphasis added. *Vom Kriege*, pp. 810-811.

28. "Was sich die Theorie hier sagen kann, ist folgendes: Es kommt darauf an, die vorherrschenden Verhältnisse beider Staaten im Auge zu haben. Aus ihnen wird sich ein gewisser Schwerpunkt, ein Zentrum der Kraft und Bewegung bilden, von welchem das Ganze abhängt, und auf diesen Schwerpunkt des Gegners muß der gesammelte Stoß aller Kräfte gerichtet sein." *Vom Kriege*, p. 976. Emphasis added.

Compare: "What the theorist has to say here is this: one must keep the dominant characteristics of both belligerents in mind. Out of these characteristics a certain center of gravity develops, *the hub of all power and movement*, on which everything depends. That is the point against which all our energies should be directed." *On War*, pp. 595-596.

29. "Weil Blücher, obgleich schwächer als Schwarzenberg, doch wegen seines Unternehmungsgestes der Bedeutendere war, daß in ihm also mehr der Schwerpunkt lag, der das Übrige in seiner Richtung mit fortreibt." Emphasis added. *Vom Kriege*, p. 324.

30. David G. Chandler, *The Campaigns of Napoleon*, New York: MacMillan, 1966, pp. 960-976.

31. "Alexander, Gustav Adolf, Karl XII, Friedrich der Große hatten ihren Schwerpunkt in ihrem Heer, wäre dies zertrümmert worden, so würden sie ihre Rolle schlecht ausgespielt haben; bei Staaten, die durch innere Parteiungen zerrissen sind, liegt er meistens in der Hauptstadt; bei kleinen Staaten, die sich an mächtige stützen, liegt er im Heer dieser Bundesgenossen; bei Bündnissen liegt er in der Einheit des Interesses; bei Volksbewaffnung in der Person der Hauptführer und in der

öffentlichen Meinung. Gegen diese Dinge muß der Stoß gerichtet sein. Hat der Gegner dadurch das Gleichgewicht verloren, so muß ihm keine Zeit gelassen werden, es wieder zu gewinnen; der Stoß muß immer in dieser Richtung fortgesetzt werden, oder mit anderen Worten, der Sieger muß ihn immer ganz und das Ganze nicht gegen einen Teil des Gegners richten." *Vom Kriege*, pp. 976-977.

32. Joint Forces Command, J9 Joint Futures Lab, *Rapid Decisive Operations White Paper*, Coordinating Draft dated August 9, 2001, Norfolk, VA: U.S. Joint Forces Command, 2001. It defines EBO as "A process for obtaining a desired strategic outcome or 'effect' on the enemy, through the application of the full range of military and non-military capabilities at the tactical, operational, and strategic levels. An 'effect' is the physical, functional, or psychological outcome, event, or consequence that results from a specific action or actions." p. A-2. However, the USAF currently has a vision of EBO that differs from that of the J9. Bruce Rolfsen, "'Effects-Based Operations' Is New Way To Fight," *Air Force Times*, May 7, 2001, p. 27.

33. Christian Lowe, "In Exercise, U.S. Military Practices Unconventional Warfare," *Defense Week*, May 21, 2001, p. 2.

34. Lowe, "Unconventional Warfare," p. 2.

35. "Diese *Centra gravitatis* in der feindlichen Kriegsmacht zu unterscheiden, ihre Wirkungskreise zu erkennen, ist also ein Hauptakt des strategischen Urteils. Man wird sich nämlich jedesmal fragen müssen, welche Wirkungen das Vorgehen und Zurückgehen des einen Teiles der gegenseitigen Streitkräfte auf die übrigen hervorbringen wird." *Vom Kriege*, pp. 810-811.

36. Based on the author's research for a forthcoming manuscript entitled, *The German Way of War*.

37. "Denn nur durch diese Entscheidung werden die Schwerpunkte der gegenseitigen Macht und die von ihnen ausgehenden Kriegstheater wirksame Dinge." *Vom Kriege*, p. 813.

38. Cited from Seow Hiang Lee, "Center of Gravity or Center of Confusion: Understanding the Mystique," Wright Flyer Paper No. 10, Maxwell Air Force Base, AL: Air Command and Staff College, 1999, pp. 18-19.

39. These strategic objectives are condensed. The objectives for the Gulf War as outlined by President Bush were: (1) withdrawal of Iraqi forces from Kuwait, (2) restoration of legitimate government in Kuwait,

(3) assuring security and stability of the Persian Gulf region, and (4) protecting American lives. Eliot Cohen, *et al.*, *Gulf War Air Power Survey*, 5 Vols., *Vol. I: Planning and Command and Control*, Washington, DC: U.S. Government Printing Office, 1993, pp. 83-84.

40. Numerous methods, too many to list here, have been devised over the years. The "Strategic Helix" method, for example, involves attacking all potential CoGs until the real one is hit. Put simply, this method amounts to a "recon by destruction" approach and assumes unlimited resources. Discussed in detail in Lee, *Center of Gravity or Center of Confusion*, pp. 27-28. Similarly, the "Onion method" amounts to little more than eating one's way through the multiple "layers" of the enemy's national power to get at the CoG. Colin Agee, *Peeling the Onion: The Iraqis' Center of Gravity*, Ft. Leavenworth, KS: School of Advanced Military Studies, 1992, pp. 26-27. Both of these methods assume that the enemy's CoG lies *within* the Helix or the Onion.

41. Mike Boettcher, "Al Qaeda forming new cells worldwide," *CNN.com*, July 31, 2002; accessed August 1, 2002. The article reported that "the new 'super cells' operate on their own without guidance from the men who once trained and directed them."

42. Al-Qa'ida, the Base, available from [http://www.ict.org.il/inter\\_ter](http://www.ict.org.il/inter_ter), Internet, accessed April 3, 2002.

43. Defense Secretary Donald H. Rumsfeld said as much in a press interview, "Secretary Rumsfeld Interview," *Washington Times*, July 19, 2002; and in a question and answer period that followed his testimony to the Senate Armed Services Committee on July 31, 2002.

**U.S. ARMY WAR COLLEGE**

**Major General Robert R. Ivany  
Commandant**

**\*\*\*\*\***

**STRATEGIC STUDIES INSTITUTE**

**Director  
Professor Douglas C. Lovelace, Jr.**

**Director of Research  
Dr. Steven Metz**

**Author  
Lieutenant Colonel Antulio J. Echevarria II**

**Director of Publications  
Ms. Marianne P. Cowling**

**Publications Assistant  
Ms. Rita A. Rummel**

**\*\*\*\*\***

**Composition  
Ms. Kimberly A. Rockwell**